

Isometric View

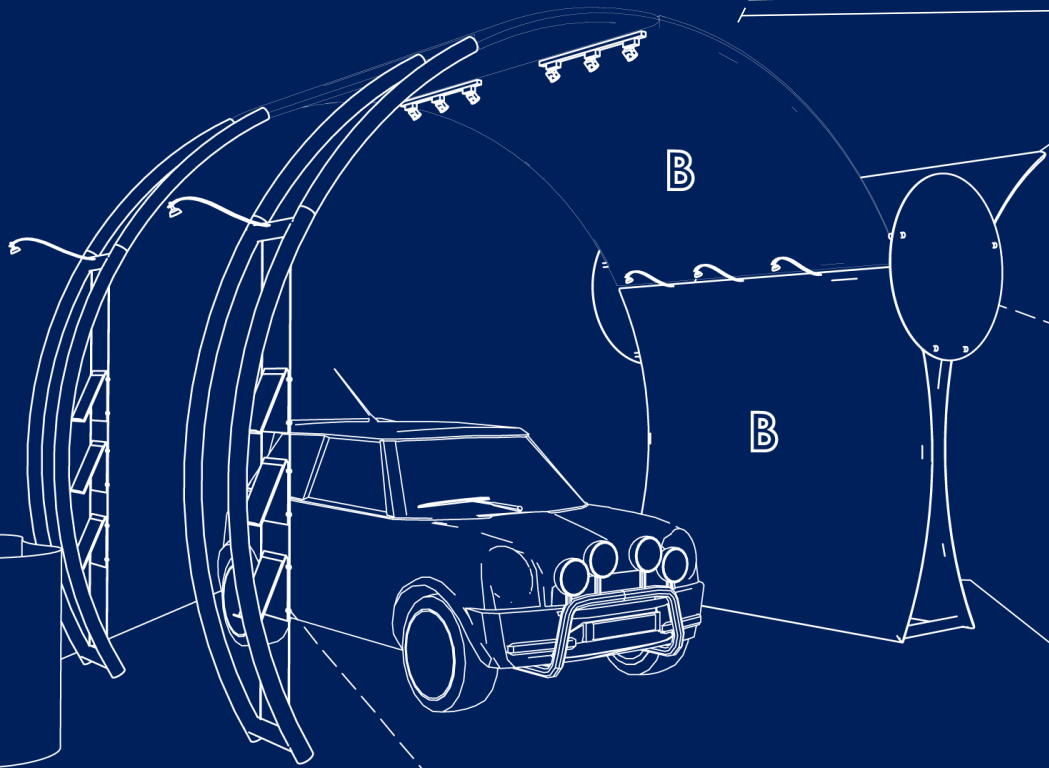
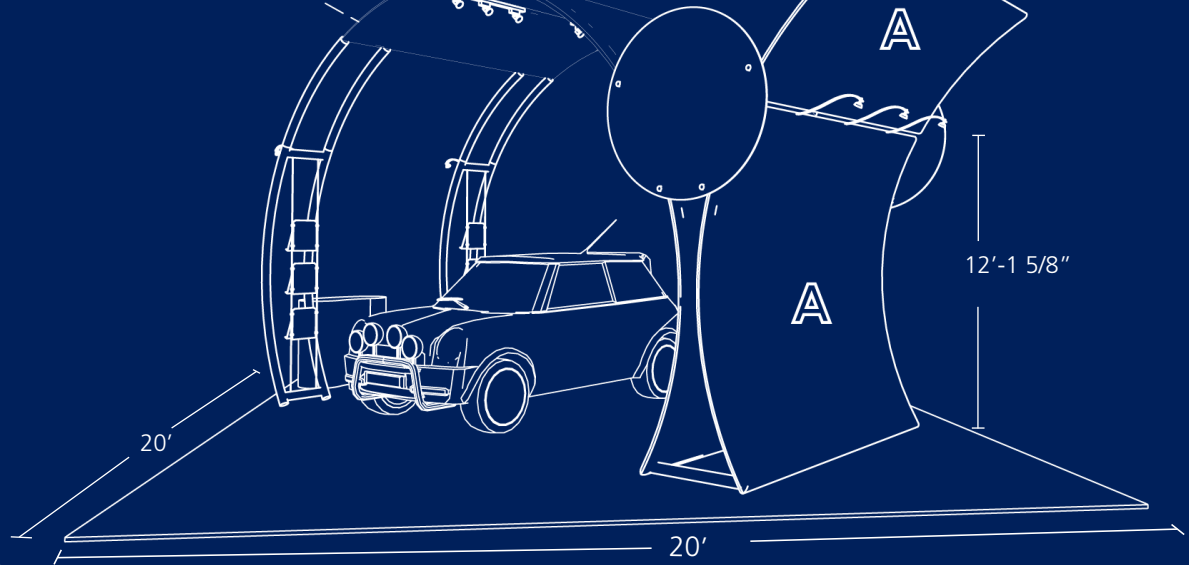

pillowcase fabric graphic
approx. 13' x 9'

rigid graphic

nimlok[®]
guide to island exhibits

ISLAND EXHIBITS

Whether an exhibitor is looking to make a “wow” statement with their brand, launch new products or services or make sales on the show floor, an island trade show exhibit can help exhibitors achieve their trade show goals. Island exhibits are not only one of the most popular exhibit types, they are also incredibly flexible and functional and can offer exhibitors a multitude of layout options and configurations for maximum impact.



Trilliant, 20' x 50'



Westinghouse, 20' x 20'



Ductmate, 20' x 50'

Before an exhibitor begins planning for and working with a partner to design an island exhibit, it is important to understand the most popular layouts and how to get the most out of the exhibiting experience. Nimlok's [Guide to Island Exhibits](#) explores four of the most commonly utilized island exhibit layouts to help an exhibitor select the perfect configuration for their company.

GOALS OF AN EXHIBITOR

Setting well-defined goals can help exhibitors select the layout and exhibit components needed to achieve their objectives. There are a multitude of trade show goals, most of which fall into one, or a combination of the following three categories.

WOW-ORIENTED >> Wow-oriented goals are for exhibitors looking to make a splash on the trade show floor with a captivating exhibit to draw visitors in to learn about new product launches, company rebranding or other major initiatives.

ENGAGE-ORIENTED >> Engage-oriented goals center around exhibitors who want to educate prospects and clients on the show floor. From networking, to hands-on demonstrations to formal presentations, engage-oriented goals look to inform and educate visitors about products, services and more.

SELL-ORIENTED >> Sell-oriented goals are for exhibitors looking to sell products or services on the show floor. These exhibitors are not only looking to show off their products and tout capabilities but they also want to turn their tradeshow space into a marketplace.



EXHIBIT BASICS

Island trade show exhibits are surrounded by aisles. Island exhibits are sold in variety of sizes, but typical dimensions are 20ft x 20ft, 30ft x 30ft and 40ft x 40ft. The cubic content of the space may be used to the maximum allowable height of a venue, which typically spans between around 18ft and 24ft, depending on the venue and show rules. Refer to the specific show booth configuration regulations for exact rules, height restrictions and guides to follow for the show.

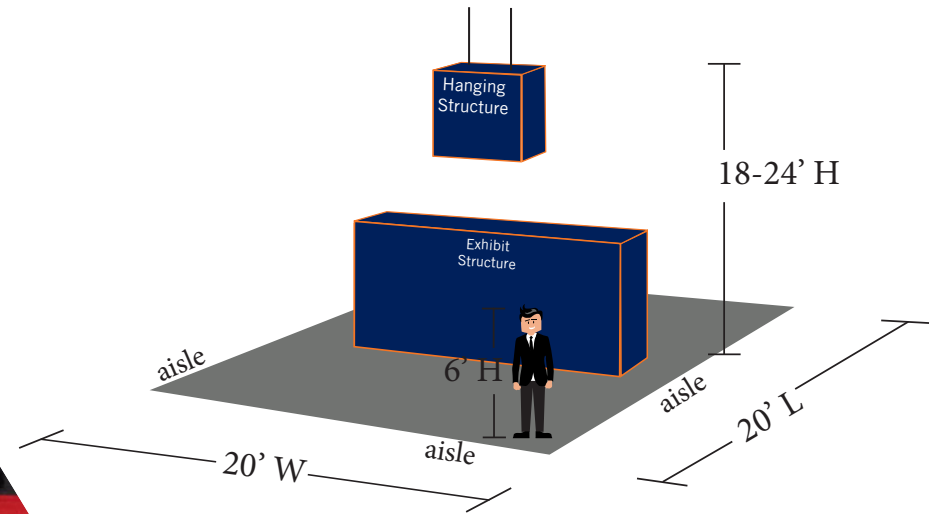

Displaydata, 20' x 20'

CANOPIES \ HANGING STRUCTURES

COMMON STRUCTURAL ELEMENTS OF AN ISLAND EXHIBIT

Canopies:

Canopies are used as architectural design accents and may function as shading for computer monitors from ambient light to allow for a better viewing experience. The base of a canopy structure typically should not be lower than 7ft from the floor or within 5ft of any aisle. Fire and safety regulations in many facilities strictly govern the use of canopies, so consult show management when incorporating canopies in your exhibit design.

Hanging Structures and Signs:

Hanging structures and signs are used to broadcast logos and showcase taglines and identifying information. The show management rules guide the height restrictions, which are typically between 18 and 24 feet. Make sure your hanging structure is rigged to the proper height per the design and per the Show's rules. Sometimes a request for variance can be applied for before electing to use a hanging structure.



Scotsman, 20' x 50'



PLT, 20' x 30'

TOWERS \ KIOSKS

COMMON STRUCTURAL ELEMENTS OF AN ISLAND EXHIBIT

Towers:

Towers often support other structural elements of an exhibit and can also be a freestanding design element. Towers are used for secure in-exhibit storage and as multimedia centers for video presentations. Strategically placed tower structures draw attention to island exhibits and allow exhibitors to project their presence across the show hall.

Kiosks:

Like towers, kiosks are freestanding design elements and can be critical to the overall exhibit integrity and structure. Kiosks enable visitors to engage with exhibitors through multimedia, such as promotional videos, touchscreen navigation of a company website or through online registrations. They add another dimension to an island exhibit, functioning as ideal platforms for multimedia presentations and engagement.



Rofin, 40' x 40'



Cogentix, 20' x 20'

TYPICAL ISLAND LAYOUT #1

THE AXIS

The **Axis Layout** features a centralized structure that serves as the axis point for the exhibit design, with independent structural elements and attendee engagement points positioned near the corners and the perimeter of the exhibit. This opens the exhibit space and allows attendee traffic to flow organically.

The central axis point is commonly a tower or structure that features signage or other brand identification and can include components like in-booth storage, information desks, hospitality areas or conference rooms.

The Axis Layout is very effective for exhibitors with **Engage-oriented goals**, as well as goals to highlight multiple product and service offerings, corporate divisions or messages.



Design Tip:

>> Education-focused kiosks, reception counters, lightbox towers and multimedia centers make for ideal perimeter structures.

TYPICAL ISLAND LAYOUT #2

THE CENTERPIECE

The **Centerpiece Layout** attracts the attention of attendees utilizing a single focal point such as a product on display or a specific brand message. The way the focal point is displayed can vary from exhibit to exhibit. Pedestals, stages or fabric structures are common focal point elements.

The simplicity of the Centerpiece Layout can help attendees focus on an exhibitor's message free of distractions, creating an atmosphere perfect for conversation and engagement.

For exhibitors with **Wow-oriented goals**, the Centerpiece Layout is an ideal solution, as it allows for large, dramatic structures that can draw attention on a busy show floor.



Dinan, 20' x 20'

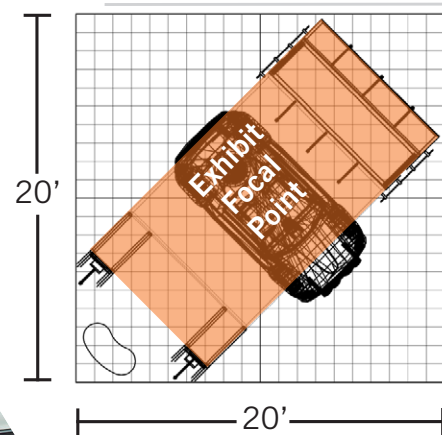

Design Tip:

>> Frame the focal point with graphic murals that support and showcase the primary message.

TYPICAL ISLAND LAYOUT #3

THE PRESENTER

The core purpose of the **Presenter Layout** is to engage a trade show audience through education or product or service demonstrations, ultimately with the goal of establishing thought-leadership.

The location of a theater or presentation area can vary. Additional exhibit structures, such as multimedia kiosks that display show times, product/service information stations and client consultation areas are often incorporated into the space.

The Presenter Layout is ideal for exhibitors with **Engage-oriented goals** who are looking to tell a story and communicate detailed information in an engaging way.



Design Tip:

>> Be careful with lighting. Too much light can obstruct viewing and too little will leave attendees in the dark. Use lighting to captivate, but be sensitive about placement.

TYPICAL ISLAND LAYOUT #4

THE PLAZA

The **Plaza Layout** provides exhibitors with a welcoming open atmosphere and often leverages internal aisles as a means of showcasing products for sale. The position of the exhibit typically features a clearly-defined pathway for attendees so they can easily view products and navigate the space.

The Plaza Layout is ideal for exhibitors with **Sell-oriented goals**, as it encourages attendees to browse/purchase products much like they would in a marketplace, mall or retail space. It also is the ideal layout for booth staff to answer questions, showcase products and make a sale.



Design Tip:

>> Keep the pathway clear and open to facilitate seamless traffic flow and product browsing.

PARTNER WITH **nimlok** TODAY



Nimlok has over 45 years of experience designing and building some of the most innovative and creative island trade show exhibits. Nimlok dealer experts can help you find the perfect island exhibit solution for your brand's unique exhibiting needs. Partner with Nimlok today and see why no one understands exhibiting better!